



# CONSUMER'S FILTER MANUAL

## STORM SERIES



Manufactured by:  
**HELLENBRAND**

404 Moravian Valley Road, Waunakee, WI 53597  
hellenbrand.com

---

---

This owner’s manual is designed to assist owners and installers with the operation, maintenance and installation of your new water filter. It is our sincere hope that this manual is clear, concise and helpful. Detailed instructions on general operating conditions, pre-installation and installation instructions, start-up, and meter programming are included. We have included a troubleshooting guide, service instructions and parts diagrams to assist future needs.

**In the event that you need professional assistance for servicing your water filter, please contact the dealer who installed this system.**

## **TABLE OF CONTENTS**

General Specifications.....	3
Pre-Installation Check List.....	4
Bypass Valve Operation .....	4
Startup Instructions.....	5
Operating Conditions.....	5
Specifications .....	5
Programming .....	6
Displays/Settings .....	6
Set Time of Day .....	7
Trouble Shooting .....	8
Ozone Trouble Shooting.....	8
Parts Diagrams & Installation Fittings.....	9-13
Recommended Annual Maintenance.....	14
Air Regen Specifications .....	15
Warranty .....	16

---

Dealer Name \_\_\_\_\_ Phone \_\_\_\_\_

Address \_\_\_\_\_ Email \_\_\_\_\_

---

---

Hellenbrand products are not for sale or distribution into the State of California effective 8/31/18

---

---

## GENERAL SPECIFICATIONS

### OPERATING PRESSURES

Minimum/Maximum ..... Minimum 25 psi  
Optimum Range 40-65 psi  
Maximum 100 psi

### OPERATING TEMPERATURES

Minimum/Maximum ..... 40° - 110° F

### METER

Accuracy ..... ±5%  
Flow Rate Range ..... 0.25 - 27 GPM  
Gallon Range ..... 20 - 50,000

### DIMENSIONS

Drain Line ..... 3/4" or 1" NPT  
Check Valve ..... 3/8" Poly Tube

**ELECTRICAL CURRENT DRAW AND VOLTAGE** ..... 2.0A/120V

NOTE: Operating outside of the optimum pressure range may affect system function. Contact your Hellenbrand support team for information.

# PRE-INSTALLATION CHECK LIST

(All electrical & plumbing should be done in accordance to all local codes)

Storm is limited to indoor installations

**Water Pressure:** A minimum of 25 pounds of water pressure (psi) is required for regeneration. Maximum pressure 100 psi.

**Water Quality:** On rural water supplies there is often a problem with sand or sediment in the water. (This problem occasionally occurs in public water supplies.) Sand and sediment may plug the filter, restricting the flow through the media bed. **Note:** Well and/or pump problems affecting the operation of the filter and repairs are not covered under the warranty.

**Electrical:** A continuous 110 volt/60 cycle current supply is required. Make certain the current supply is uninterrupted and cannot be turned off with another switch. All electrical connections must be connected per local codes. **Surge protection is recommended with all electrical controls.**

**Existing Plumbing:** Condition of existing plumbing must be free from lime and iron build-up. Piping that is built-up heavily

with lime and/or iron must be replaced. If piping is blocked with iron, additional equipment may be needed ahead of the filter to correct the problem.

**Drain Line:** The filter should be located close to a drain. Avoid overhead drain lines if possible to prevent back pressure. Overhead drains are not to exceed 8 feet above the floor and no more than 20 feet in length. The pipe size for the drain line should be a minimum of 3/4". Backwash flow rates in excess of 10 gpm or length in excess of 20' require 1" drain line.

**Bypass Valves:** Always provide for the installation of a bypass valve.

**Caution:** Water temperature is not to exceed 110°F; the filter cannot be subject to freezing conditions, or to a vacuum due to loss of pressure (such as a water main break).

## BYPASS VALVE OPERATION

Softening - Filtering  
NORMAL OPERATION

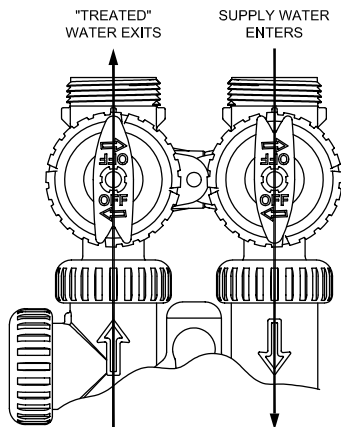

Figure 1

BYPASS OPERATION

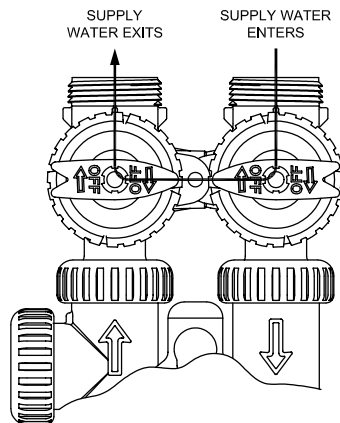

Figure 2

DIAGNOSTIC MODE

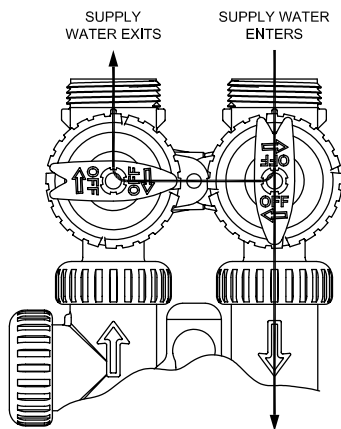

Figure 3

SHUT OFF MODE

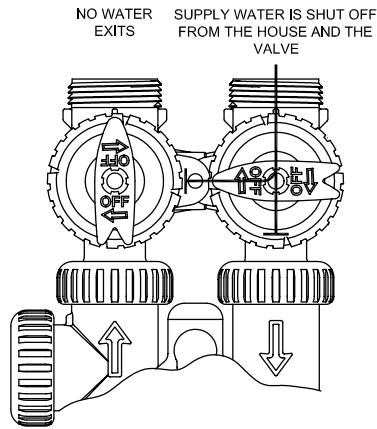

Figure 4

# Start Up Instructions

**For optimal results, allow the filter media to soak for a minimum of 12 hours prior to install. This helps to maintain the manufacturer's specified filtration properties.**

1. Complete all plumbing connections; inlet, outlet and drain line.
2. Place bypass valve in bypass position. Turn on main water supply and open a cold filtered faucet to flush piping of any air and/or foreign material. Run until water is clear.
3. Open inlet valve slowly on bypass until it is in fully open service position. Let water run to drain until clear. Plug unit into 120V outlet and remove cover and plug transformer connection into 4-prong connection on circuit board labeled power. Valve will return to service position once this connection is made.
4. Let media soak for 15 minutes before proceeding.

5. Initiate backwash by holding "REGEN" button down until piston movement is heard.
6. Let backwash continue until cycle is done. When "RINSE" is displayed, push the REGEN button again to move into the SERVICE position. Let the system settle for 5 minutes.
7. Repeat the backwash and settle steps (5&6) for a total of three times.

NOTE: It takes several backwash cycles before all the media fines are removed. Elimination of the 12 hour soak procedure may result in more backwash cycles required to remove the media fines.

**Failure to follow proper start-up may result in equipment malfunction not covered by warranty.**

# Operating Conditions

**pH** — The pH level of the influent water must be 7.0 or higher for iron oxidation reaction to proceed per the engineering specifications.\*

**Iron** — This system is rated for 6.0 ppm of ferrous (clear water) and/or ferric (red water) iron.\*

**Hydrogen Sulfide** — Sometimes referred to as "rotten egg" odor. This system is rated for 5.0 ppm hydrogen sulfide. Hydrogen sulfide levels vary depending on barometric pressure.\*

**Manganese** — Limit 1.0 ppm; amounts present over 1.0 ppm may gradually prevent iron removal. Note: For optimum manganese reduction, pH should be greater than 8.5.\*

**Organic Matter (Tannins)** — The presence of organic matter such as tannins will prevent the oxidation process of converting the dissolved element, such as iron or manganese, to a nonsoluble precipitate or solid substance. In other words, organics can tie up the iron preventing filtration. **The presence of organics such as tannins above 0.5 ppm voids any claims for this system to perform as stated above. In some applications, tannin levels below 0.5 ppm or the presence of other organics may hinder the operation of this system.\***

**Total Dissolved Solids (TDS)** — While TDS does not directly affect iron removal, it is a good indicator of potential interference. Most waters have TDS less than 500 and generally present no problems to iron reduction. If any ion becomes excessive, it may cause failure of iron removal. **A TDS more than 500 ppm voids any claims for this system to perform as stated above.\***

**\*For application parameters outside the specified operation conditions or additional information regarding the listed items, contact your dealer.**

**Do not install on chlorinated water supplies - harmful by-products may be formed with ozone.**

**This unit is not intended to aid in the mitigation of microorganisms and is not duly registered as a pesticidal device.**

**The Storm ozone filter must not be used on bacteriologically unsafe water supplies, such as those with with positive Coliform or E Coli bacteria tests.**

**Small amounts of hardness (0.5-2 gpg) may occur initially when filters installed on soft water.**

<b>Specifications</b>	<b>Filter Tank Size</b>	<b>Media Cu. Ft</b>	<b>Inlet/Outlet</b>	<b>Max. Service Flow GPM</b>	<b>(1) Backwash Rate GPM</b>
<b>Iron Storm Models</b>					
<b>Iron Storm-10</b>	10"x54"	1.0	1"	4	5.3
<b>Iron Storm-12</b>	12"x52"	1.6	1"	6	7.5
<b>Iron Storm-13</b>	13"x54"	1.9	1"	7	10

(1) Water temps above 60° F will require a higher backwash rate. Consult factory.

## Backwash Frequency

### Iron Applications

- 0.3 - 2.0 ppm Iron - Every 3rd Day
- 2.0 - 4.0 ppm Iron - Every Other Day
- 4.0 - 6.0 ppm Iron - Every Day

## Ozone Recharge Frequency

### Hydrogen Sulfide Applications

- 0.1 - 1.0 ppm Hydrogen Sulfide - 100 Gallon
- 1.0 - 5.0 ppm Hydrogen Sulfide - 50 Gallon

# PROGRAMMING

## General Information

The control valve is the “brain” of your water filter. It consists of the valve body and powerhead with solid state microprocessor.

The display panel (see Figure 5) consists of the LCD display and five push buttons which are used in displaying and programming the water filter settings.

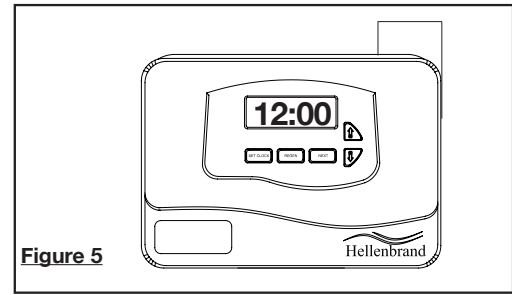

Figure 5

## USER DISPLAYS/SETTINGS

### General Operation

When the system is operating, one of three displays may be shown. Pressing NEXT will alternate between the displays. One of the displays is the current time of day. The second display is one of the following: days to a regen or gallons remaining. Days To A Regen is the number of days left before the system goes through a regeneration cycle. Capacity remaining is the number of gallons that will be treated before the system goes through a regeneration cycle. The third display is current flow in gal/min. The user can scroll between the displays as desired by pushing NEXT or display will scroll automatically.

When water is being treated (i.e. water is flowing through the system) the word "GPM" flashes on left side of display when other than flow rate is displayed.

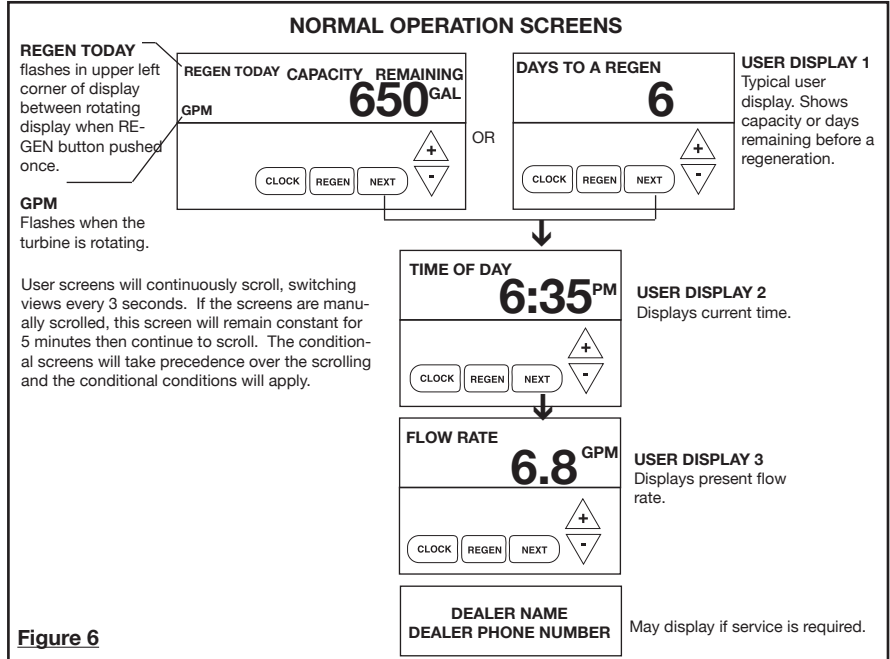

Figure 6

### Regeneration Mode

Typically a system is set to regenerate at a time of low water usage. An example of a time with low water usage is when the household is asleep. If there is a demand for water when the system is regenerating, untreated water will be supplied. If water is being used when regeneration starts, there may be a momentary delay in flow as old head of air is being expelled from the system.

When the system begins to regenerate, the display will change to include information about the step of the regeneration process and the time remaining for that step to be completed. The system runs through the steps automatically and will reset itself to provide treated water when the regeneration has been completed.

### Manual Regeneration

Sometimes there is a need to regenerate the system, sooner than when the system calls for it, usually referred to as manual regeneration. This is usually due to period of heavy water usage.

To initiate a manual regeneration at the preset delayed regeneration time, press and release “REGEN”. The words “REGEN TODAY” will flash on the display to indicate that the system will regenerate at the preset delayed regeneration time. If you pressed the “REGEN” button in error, pressing the button again will cancel the request.

To initiate a manual regeneration immediately, press and hold the “REGEN” button for three seconds. The system will begin to regenerate immediately. The request cannot be cancelled. You must cycle all the way through the cycles to make it stop. PLEASE NOTE: This will reset the meter.

Regeneration Step #2  
(shows time remaining in “Backwash” is 8:22)



Figure 11

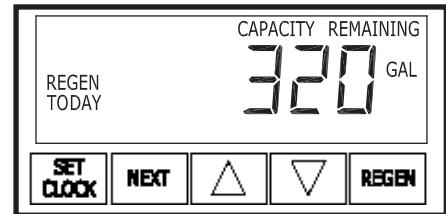
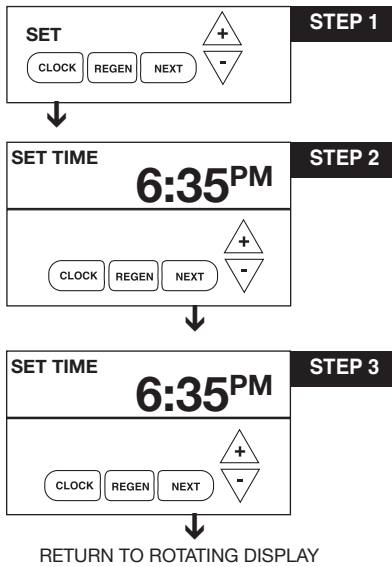

Figure 7

## SET TIME OF DAY

▲ = ▲ Up Arrow    ▼ = ▼ Down Arrow



**Step 1** - Press SET CLOCK.

**Step 2** - Current Time (**hour**): Set the hour of the day using ▲ or ▼ buttons. AM/PM toggles after 12. Press NEXT to go to step 3.

**Step 3** - Current Time (**minutes**): Set the minutes of day using ▲ or ▼ buttons. Press NEXT to exit Set Clock. Press REGEN to return to previous step.

**Power Loss** - Lithium battery on circuit board provides up to 2 years of time clock backup during power outages. If the power is out when battery is depleted, only time of day needs to be reset, all other values are stored in non-volatile memory. When time of day is flashing, replace lithium coin type 2032 battery.

Battery back-up feature will be activated after 24 hours of power.

Do not forget to reset for daylight savings time.

# TROUBLE SHOOTING

PROBLEM	CAUSE	CORRECTION
1. Control valve stalled in regeneration	<ul style="list-style-type: none"> <li>A. Motor not operating</li> <li>B. No electric power at outlet</li> <li>C. Defective transformer</li>   <li>D. Defective PC board</li> <li>E. Broken drive gear or drive cap assembly</li> <li>F. Broken piston retainer</li> <li>G. Broken main or regenerant piston</li> </ul>	<ul style="list-style-type: none"> <li>A. Replace Motor</li> <li>B. Repair outlet or use working outlet</li> <li>C. Should provide 12 volts when plugged into outlet, if not, replace transformer</li> <li>D. Replace PC board</li> <li>E. Replace drive gear or drive cap assembly</li> <li>F. Replace drive cap assembly</li> <li>G. Replace main or regenerant piston</li> </ul>
2. Blank or incomplete LCD display	<ul style="list-style-type: none"> <li>A. Transformer unplugged</li> <li>B. No electric power at outlet</li> <li>C. Defective transformer</li>   <li>D. Short in meter</li>   <li>E. Check battery, should be greater than 3 volts</li> <li>F. Defective PC board</li> </ul>	<ul style="list-style-type: none"> <li>A. Connect to power</li> <li>B. Repair outlet or use working outlet</li> <li>C. Should provide 12 volts when plugged into outlet, if not, replace transformer</li> <li>D. Unplug meter from PC board, if LED lights appropriately, replace meter assembly.</li> <li>E. Replace battery if less than 3 volts</li> <li>F. Replace PC board</li> </ul>
3. Control does not display correct	<ul style="list-style-type: none"> <li>A. Power outage &gt; 2 years time of day</li> <li>B. Power outage &lt; 2 years, time of day flashing, battery depleted</li> </ul>	<ul style="list-style-type: none"> <li>A. Reset time of day, replace lithium coin type battery on circuit board</li> <li>B. Reset time of day, replace lithium coin type battery on circuit board</li> </ul>
4. No "filtering" display when water is flowing	<ul style="list-style-type: none"> <li>A. Bypass valve in bypass position</li> <li>B. Meter connection disconnected</li> <li>C. Restricted/stalled meter turbine</li> <li>D. Defective meter</li> <li>E. Defective PC board</li> </ul>	<ul style="list-style-type: none"> <li>A. Put bypass valve in service position</li> <li>B. Connect meter to PC board</li> <li>C. Remove meter &amp; check for rotation, clean foreign material</li> <li>D. Replace meter</li> <li>E. Replace PC board</li> </ul>
5. Control valve regenerates at wrong time of day	<ul style="list-style-type: none"> <li>A. Power outages</li> <li>B. Time of day not set correctly</li> <li>C. Time of regeneration incorrect</li> <li>D. Control valve set at "on 0" (immediate regeneration)</li> <li>E. Control valve set at NORMAL + on 0</li> </ul>	<ul style="list-style-type: none"> <li>A. Reset control valve to correct time of day</li> <li>B. Reset to correct time of day</li> <li>C. Reset regeneration time</li> <li>D. Check control valve set-up procedure regeneration time option</li> <li>E. Check control valve set-up procedure regeneration time option</li> </ul>
6. Odor bleedthrough	<ul style="list-style-type: none"> <li>A. Test for Hydrogen Sulfide (H<sub>2</sub>S) on site.</li> </ul>	<ul style="list-style-type: none"> <li>A. Hydrogen Sulfide bleedthrough                             <ul style="list-style-type: none"> <li>1. Increase frequency of ozone recharge</li> <li>2. Exceeding flow rate specification - see page 6</li> <li>3. No ozone present - see Ozone Generator troubleshooting</li> </ul> </li> <li>B. No Hydrogen Sulfide after unit Bacteria is source of odor rather than H<sub>2</sub>S, chlorinate distribution plumbing and flush completely</li> </ul>
7. Momentary reduction of water pressure at the start of regeneration	<ul style="list-style-type: none"> <li>A. Head of air being expelled to drain</li> </ul>	<ul style="list-style-type: none"> <li>A. Reprogram regeneration to a time when water is not being used</li> </ul>

# OZONE GENERATOR TROUBLESHOOTING GUIDE

SYMPTOM	POSSIBLE CAUSE	CORRECTION
1. Ozone unit does not turn on	<ul style="list-style-type: none"> <li>A. Unit not wired correctly to relay</li> <li>B. Unit not programmed correctly</li>   <li>C. Blown fuse</li> </ul>	<ul style="list-style-type: none"> <li>A. See wiring diagram on page 18</li> <li>B. See program on page 11. Relay should be programmed on Time. Usually set to 19 minutes. Duration should be programmed for 2 minutes less than length of time to draw ozone to top of filter bed.</li> <li>C. Replace fuse with equally rated fuse, see page 18</li> </ul>
2. Unit keeps blowing fuses	<ul style="list-style-type: none"> <li>A. Electrical short in unit</li>   <li>B. Incorrect fuse value and type are being used</li> <li>C. Unit is connected to improper power source</li> </ul>	<ul style="list-style-type: none"> <li>A. Visually inspect unit, and check for loose connections. Inspect printed circuit board for burn marks. Inspect high voltage wire from printed circuit board to ozone cell for disconnection or burn marks. Repair any and all problems prior to placing unit in service or contact factory for service information</li> <li>B. Replace with appropriate size/type fuse. Refer to Spare/Replacement parts for replacement part information on page 18</li> <li>C. Refer to ozone generator manual for correct voltage requirements</li> </ul>
3. Unit turns on, but no ozone output	<ul style="list-style-type: none"> <li>A. Cell is plugged with a build-up of nitrous byproducts and particulate matter. Usually caused by the lack of proper air preparation</li> <li>B. Water has been allowed to back up into cell</li> <li>C. Frequency driver high voltage lead(s) is not connected to ozone cell(s)</li> <li>D. Frequency driver is defective</li> </ul>	<ul style="list-style-type: none"> <li>A. Rinse cells with warm water and dry completely before replacing</li> <li>B. Replace cell/check valve</li> <li>C. Connect lead(s) to Corona Discharge Cell(s)</li> <li>D. Replace circuit board driver</li> </ul>



# PM6 IC STORM

Item	Description	Qty	Part #
1	Metered Control	1	110270, specify flow control
3&4	Mineral Tank Assembly		
	IC-Storm 1054 Filter Tank	1	104022 Tank & Distributor Tube Only
	IC-Storm 1252 Filter Tank	1	108294 Tank & Distributor Tube Only
	IC-Storm 1354 Filter Tank	1	108295 Tank & Distributor Tube Only
	Replacement Tank with Media	1	110541 IC Storm 10 Tank, Natural, Vortech Standard with Media 110542 IC Storm 12 Tank, Natural, Vortech Standard with Media 110543 IC Storm 13 Tank, Natural, Vortech Standard with Media
5	Filter Media		110544 IC Storm 10 Rebed 110545 IC Storm 12 Rebed 110546 IC Storm 13 Rebed
6	Plate Distributor - (Part of Vortech Tank)		
7	Bypass Valve	1	V3006
8	In-line Check Valve Kit	1	104174 (includes 90° vertical adapter & in-line check valve)
9	Ozone Generator	1	110547
10	Check Valve/Elbow	1	110822
11	Tank Jackets - 10"	1	106745
12	Blocker, Air WS1 CV 1.050	1	D1047

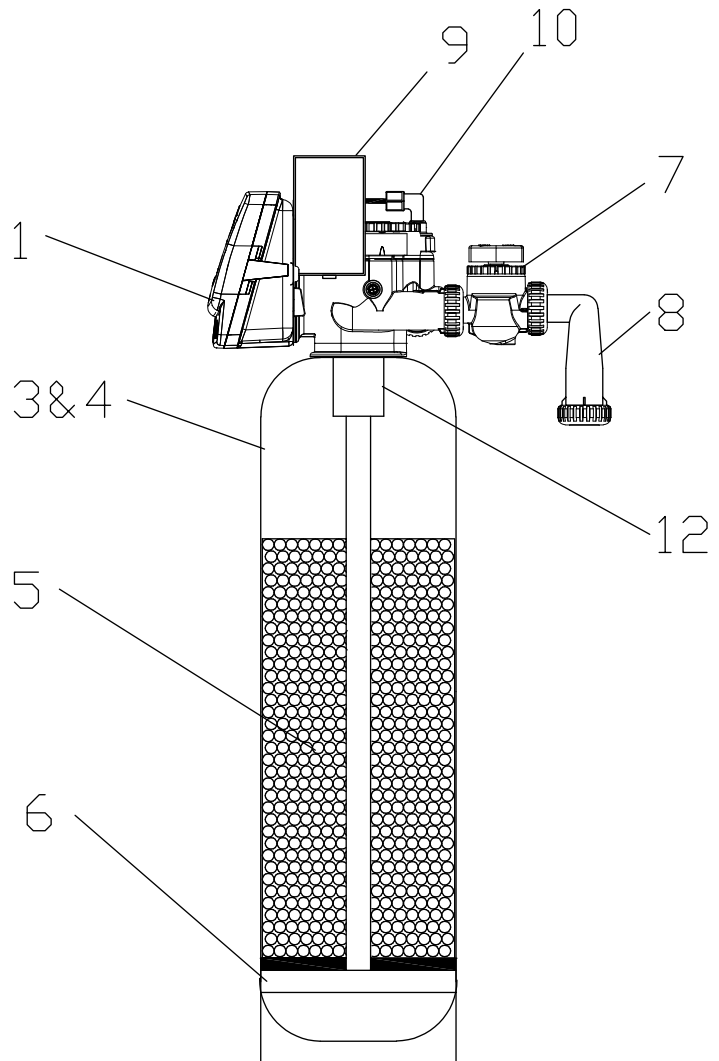

Compatible with the following regenerants or chemicals: Sodium chloride, potassium permanganate, sodium bisulfite, sodium hydroxide, hydrochloric acid and chloramines. For specific regeneration systems, contact factory.

## FRONT COVER AND DRIVE ASSEMBLY

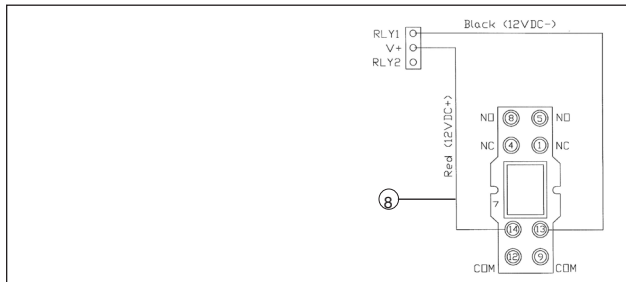

ITEM NO.	ORDER NO.	DESCRIPTION	QTY.
1	103473	PM 6.0 Cover Assy w/Label	1
2	V3107-01	Motor	1
3	101262	Drive Bracket & Spring Clip	1
4	V3578HP-02BOARD	PM 6.0 - PC Board	1
5	V3110	Drive Gear 12x36	3
6	V3109	Drive Gear Cover	1
7	103724	Relay Kit Option Installed	1
8	102385	Relay Only	1
9	110038	Battery	1
Not Shown	110409	Transformer 110V-14V	1

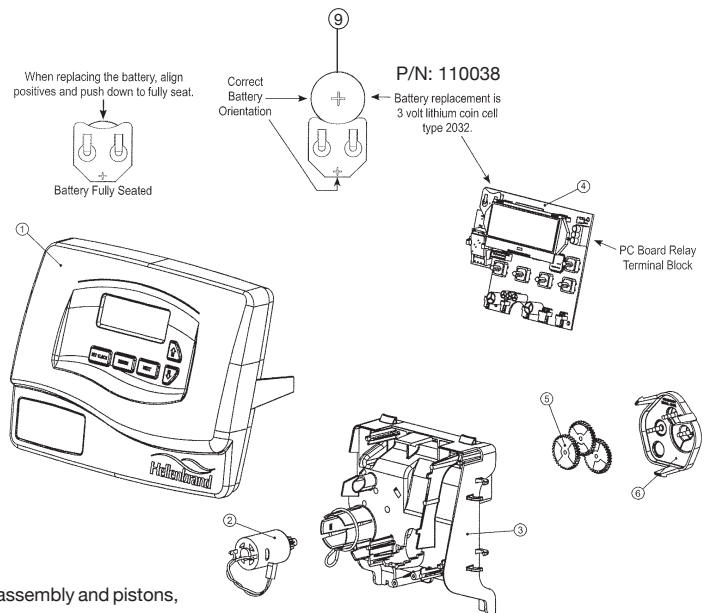

After completing any valve maintenance involving the drive assembly or the drive cap assembly and pistons, press and hold NEXT and REGEN buttons for 3 seconds or unplug power source jack from the printed circuit board (black wire) and plug back in. This resets the electronics and establishes the service piston position. The display should flash all wording, then flash the software version (ex: 214) and then reset the valve to the service position.

Figure 8

## DRIVE CAP ASSEMBLY, DOWNFLOW PISTON, REGENERANT PISTON AND SPACER STACK ASSEMBLY

ITEM NO.	ORDER NO.	DESCRIPTION	QTY.
1	V3005-02	Spacer Stack Assy	1
2	V3004	Drive Cap Assy.	1
3	V3135	O-Ring 228 -Drive Cap Assy.	1
4a	V3011	Piston Downflow Assy.	1**
4b	V3011-01	Piston Upflow Assy.	1
5	V3174	Regenerant Piston	1
6	V3180	O-ring 337-tank	1
7	V3105	O-ring - Distributor Tube	1
8	V3343	PM 6.0 Back Plate	1
9	V3193-02	Service Wrench - Not Shown	1

\*V3011 is labeled with DN and V3011-01 is labeled with UP.  
 Note: The regenerant piston is not used in backwash only applications.  
 \*\*Standard Option.

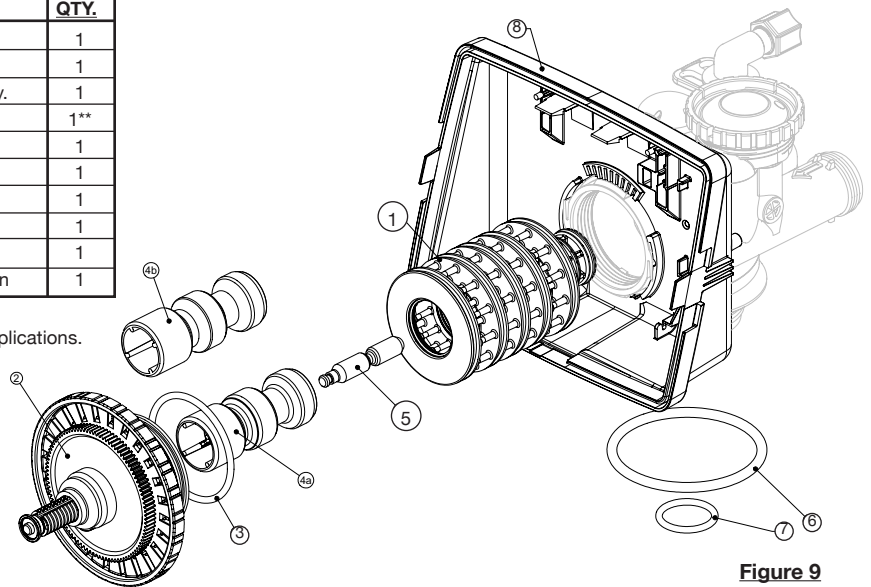

Figure 9

Do not use vaseline, oils, other hydrocarbon lubricants or spray silicone anywhere. A silicone lubricant may be used on black o-rings but is not necessary. **Avoid any type of lubricants, including silicone, on red or clear lip seals.**

After completing any valve maintenance involving the drive assembly or the drive cap assembly and pistons, press and hold NEXT and REGEN buttons for 3 seconds or unplug power source jack from the printed circuit board (black wire) and plug back in. This resets the electronics and establishes the service piston position. The display should flash all wording, then flash the software version (ex: 214) and then reset the valve to the service position.

# INJECTOR CAP, INJECTOR SCREEN, INJECTOR, PLUG AND O-RING

ITEM NO.	ORDER NO.	DESCRIPTION	QTY.
1	V3176-01	Injector Cap	1
2	V3152	O-ring 135	1
3	V3177-01	Injector Screen	1
4	V3010-1Z	Injector Assy. Z Plug-Filter	1
5	V3010-1A	Injector Assy. A Black	1
	V3010-1B	Injector Assy. B Brown	
	V3010-1C	Injector Assy. C Violet	
	V3010-1D	Injector Assy. D Red	
	V3010-1E	Injector Assy. E White	
	V3010-1F	Injector Assy. F Blue	
	V3010-1G	Injector Assy. G Yellow	
	<b>V3010-1H</b>	<b>Injector Assy. H Green</b>	
	V3010-1I	Injector Assy. I Orange	
	V3010-1J	Injector Assy. J Light Blue	
	V3010-1K	Injector Assy. K Light Green	
Not Shown	V3170	O-ring 011	*
Not Shown	V3171	O-ring 013	*

\* The injector plug and the injector each contain one 011 (lower) and 013 (upper) o-ring.

Note: For upflow position, injector is located in the up hole and injector plug in the down hole. For a filter that only backwashes injector plugs are located in both holes.

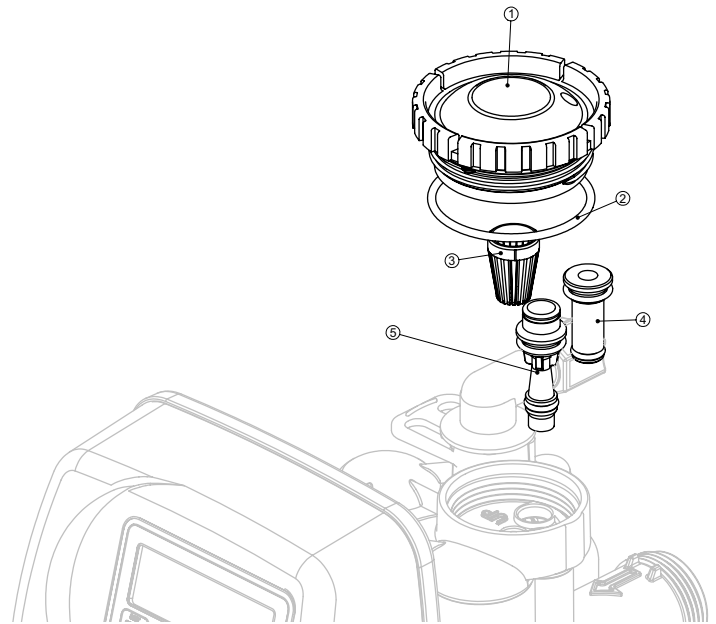
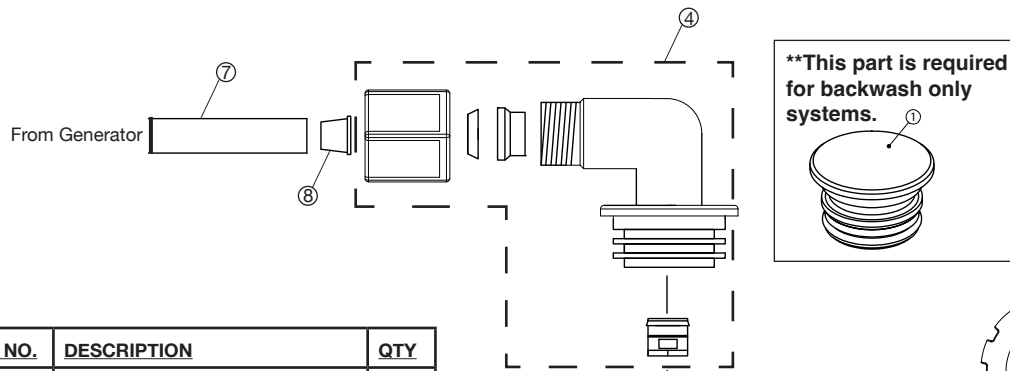

Figure 10

The nuts and caps are designed to be unscrewed or tightened by hand or with the special plastic wrench. If necessary a pliers can be used to unscrew the nut or cap. Do not use a pipe wrench to tighten or loosen nuts or caps. Do not place screwdriver in slots on caps and/or tap with a hammer.

Do not use pipe dope or other sealants on threads. Teflon tape must be used on threads of the 1" NPT connection and on the threads for the drain line connection. Teflon tape is not necessary on the nut connection nor caps because of o-rings seals.

# REFILL AND REFILL PORT PLUG



ITEM NO.	ORDER NO.	DESCRIPTION	QTY
1	V31995-01	Refill Port Plug Assy	1
2	H4615	Elbow Locking Clip	1
4	110822	Elbow, 3/8 Assy (Includes Check Valve & Nut)	1
5	V3163	O-Ring 019	1
7	111004	Tubing 3/8"	1
8	111006	Polytube Insert 5/16"	1

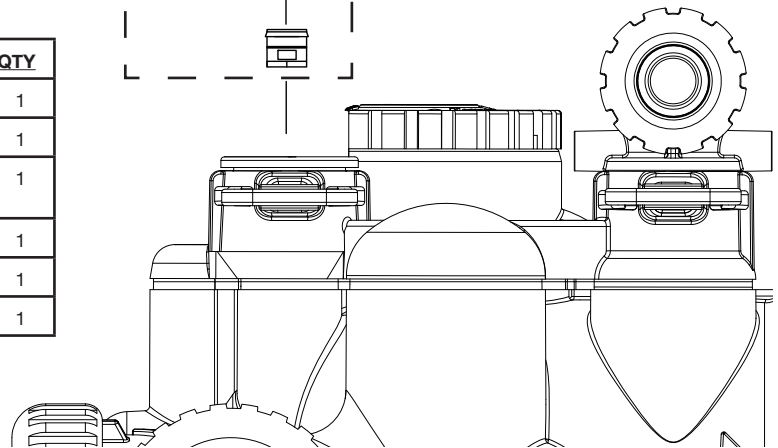

Figure 11

## DRAIN LINE - 3/4"

ITEM NO.	ORDER NO.	DESCRIPTION	QTY.
1	H4615	Elbow Locking Clip	1
2	PKP10TS8-BULK	Polytube Insert, 5/8"	Optional
3	V3192	Nut, 3/4" Drain Elbow	Optional
4-5	V3158-02	Drain Elbow 3/4" Male Asy-No Vent	1
5	V3163	O-Ring 019	1
6	V3159-01	DLFC Retainer Assy.	1
7	V3162-053	DLFC 5.3 gpm for 3/4"	1
	V3162-075	DLFC 7.5 gpm for 3/4"	
	V3162-090	DLFC 9.0 gpm for 3/4"	
	V3162-100	DLFC 10.0 gpm for 3/4"	
<b>One DLFC must be used if 3/4 fitting is used</b>			

Systems are shipped without 3/4" nut for drain elbow (polytube installation only) and 5/8" polytube insert (polytube installation only).

**Option:** V3158-01 – 3/4" Drain Elbow with Silencer Vent.

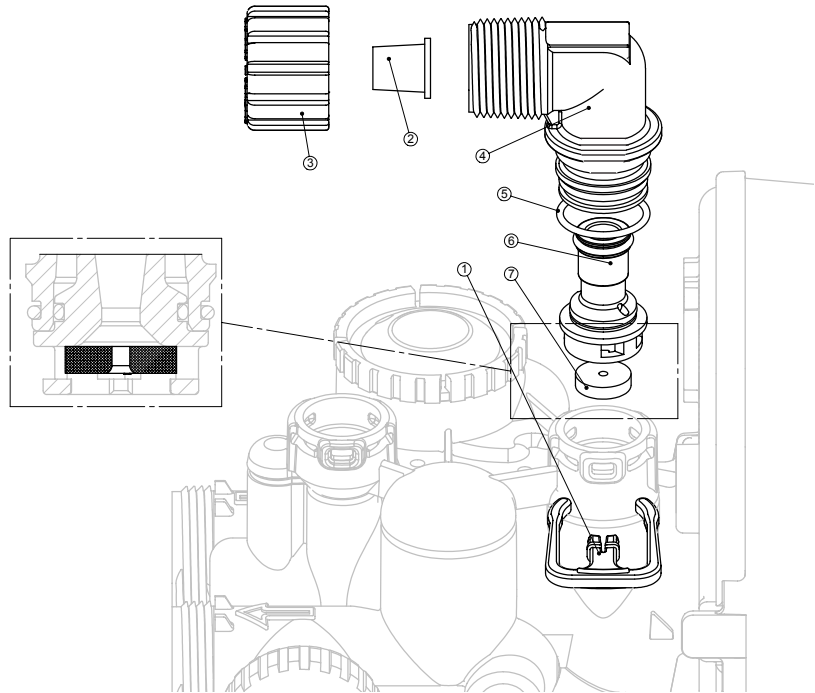

**Figure 12**

## WATER METER AND METER PLUG

ITEM NO.	ORDER NO.	DESCRIPTION	QTY.
1	V3151	Nut 1" QC	1
2-4	V3003-05*	Meter Assy.	1
3	V3118-01	Turbine Assy.	1
4	V3105	O-ring 215	1
5	V3003-01	Meter Plug Assy.**	1

\*Order number V3003-05 includes V3118-01 and V3105, which are item numbers 3 & 4.

\*\*Only used if metering is not to be done (time clock units)

The nuts and caps are designed to be unscrewed or tightened by hand or with the special plastic wrench. If necessary a pliers can be used to unscrew the nut or cap. Do not use a pipe wrench to tighten or loosen nuts or caps. Do not place screwdriver in slots on caps and/or tap with a hammer.

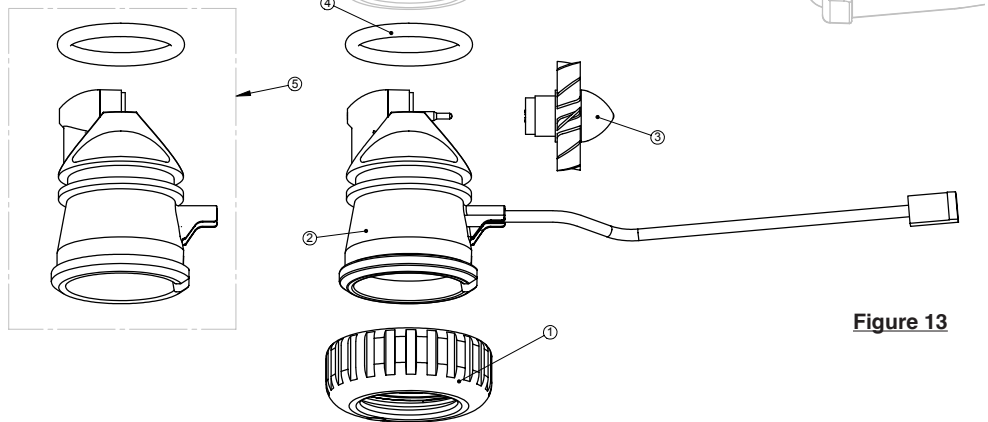

**Figure 13**

## BYPASS VALVE

ITEM NO.	ORDER NO.	DESCRIPTION	QTY.
1	V3006	Complete Bypass Assembly	

**NOTE: Individual Bypass Components Are Not Available, Must Order Complete Bypass Assembly.**

ITEM NO.	ORDER NO.	DESCRIPTION	QTY.
1	V3151	Nut 1" Quick Connect	2
2	V3150	Split Ring	2
3	V3105	O-Ring 215	2
11*	V3191-01	Bypass Vertical Adpt. Assy.	2

\*11 (Not Shown)

The nuts and caps are designed to be unscrewed or tightened by hand or with the special plastic wrench. If necessary a pliers can be used to unscrew the nut or cap. Do not use a pipe wrench to tighten or loosen nuts or caps. Do not place screwdriver in slots on caps and/or tap with a hammer.

Do not use pipe dope or other sealants on threads. Teflon tape must be used on threads of the 1" NPT connection and on the threads for the drain line connection. Teflon tape is not necessary on the nut connection nor caps because of o-rings seals.

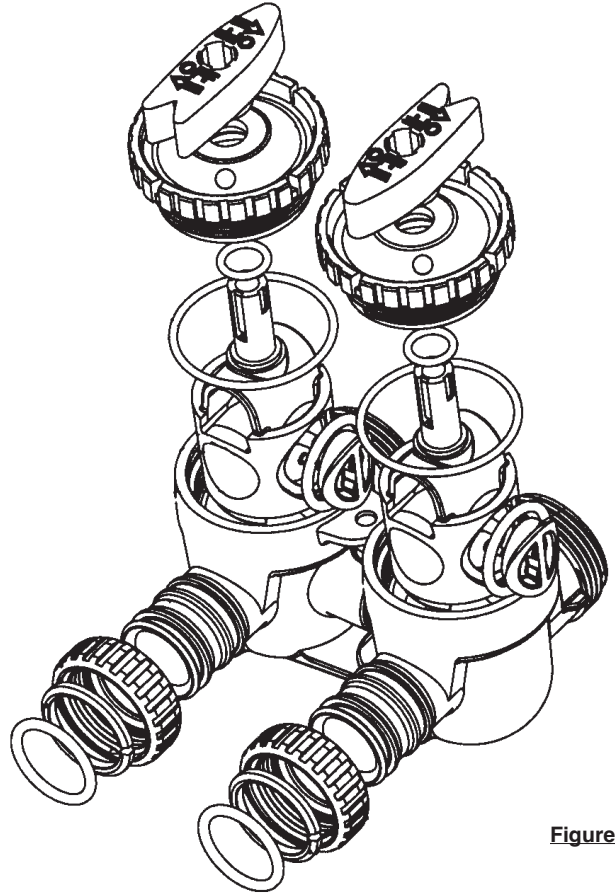
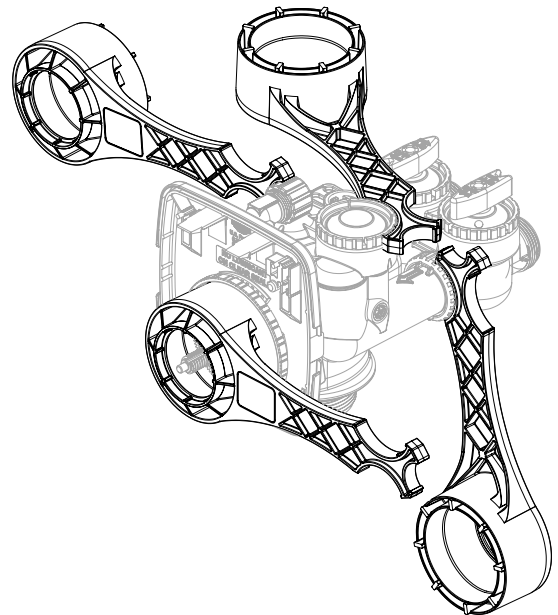

Figure 14

## WRENCH

Although no tools are necessary to assemble or disassemble the valve, the wrench (shown in various positions on the valve) may be purchased to aid in assembly or disassembly.

**V3193-02 - Wrench**



---

## RECOMMENDED ANNUAL MAINTENANCE

### Annually

- Test raw water, assure filter settings are appropriate for the application. Note and record any changes.
- Verify injector is clean and functioning. (stock code 101832)
- View head of air and determine need for cleaning inlet diffuser by running at service flow and then note difference when bypass open. If significantly different, disconnect valve from tank and clean inlet diffuser. If IRB slime or iron build-up is present, ozone level may not be adequate, check settings, check ozone production.
- Clean / change CD cell. Flush CD cells completely by pushing warm RO or soft water through CD cells to dissolve build-up inside. This can be done using a bulb syringe or large 60cc syringe. Flush until the water coming out is clear, usually takes 2-3 times. CD cell must be dry completely before it can be reinstalled or cell will not produce ozone. Verify ozone production prior to changing CD cell to understand need for cleaning frequency at each application. Initiate regeneration, attach tubing to CD cell inlet and disconnect brine elbow during draw cycle and blow on tubing to detect ozone odor. Check that indicator light is working.
- Check back wash flow is proper and water supply is maintained for the duration of the backwash cycle.
- Change ozone check valve (at brine elbow, stock code 110822).
- Change injector & clean screen.
- Confirm draw time setting draws air to top of bed.
- Check filter valve settings.
- Check diagnostic information to review any errors, address errors if present.
- Note and record any changes.
- Anticipated life of stack & piston is 5-7 years with standard ferrous and ferric applications. Iron bacteria may require more frequent maintenance.
- It is recommended to change the battery (CR2032), stock code 110038, on the control valve circuit board if it is more than two years old. This maintains time of day in the event of power loss.



## PROMATE 6 IC STORM WITH AIR REGEN SPECIFICATIONS

<i>MODEL</i>	PM6 IC Storm 10	PM6 IC Storm 12	PM6 IC Storm 13
<b>FACTORY PRESET MINUTES</b>			
Backwash # 1 : Seconds	0:10	0:10	0:10
Draw DN # 1 : Minutes	8	12	12
<b>*Water Usage (Gallons) sequence # 1</b>	6.5	9.8	10.2
BACKWASH # 2 : MINUTES	12	12	12
RINSE # 2 : MINUTES	6	6	6
DRAW DN # 2 : MINUTES	8	12	12
<b>*Water Usage (Gallons) sequence # 2</b>	100	142	187
<b>Maximum Service Flow Rate</b>	4.0	6.0	7.0
<b>Media, Cubic Feet</b>	1	1.6	1.9
<b>Mineral Tank Dimension</b>	10x54	12x52	13x54
<b>Drain Line Flow Control- GPM</b>	5.3	7.5	10
<b>Injector</b>	Dk. Green	Dk. Green	Dk. Green
<b>Max. Iron Concentration</b>	6.0	6.0	6.0
<b>Max. Hydrogen Sulfide Concentration</b>	5.0	5.0	5.0
<b>Max. Manganese Concentration</b>	1.0	1.0	1.0

\* Based upon 50 psi water pressure

\*\* **Do not use Storm filter on chlorinated water supplies.**

\*\*\*For levels higher than the maximum concentrations listed, contact manufacturer. Local water conditions may require different application parameters.

Note: Manual regeneration follow sequence # 2

**This unit is not intended to aid in the mitigation of microorganisms and is not duly registered as a pesti-  
cidal device.**

**The Storm ozone filter must not be used on bacteriologically unsafe water supplies, such as those with  
with positive Coliform or E Coli bacteria tests.**

---

# FILTER WARRANTY

## INCLUDES – Iron Curtain® 2.0, Iron Curtain® Jr. and Storm Filter Systems

Hellenbrand, warrants to the original consumer purchaser that the system and the parts listed below will be free from defects in material and/or workmanship from the date of the original installation for the following time periods:

For a Period of FIVE YEARS: The filter control valve electrical parts including the motor and board, control valve body, excluding internal parts.

For a Period of FIVE YEARS: The IC-2.0 Aeration Macromatic Timer.

For a Period of FIVE YEARS: The IC-2.0 aeration control body, excluding its internal parts, solenoid and air pump assemblies.

For a Period of TEN YEARS: The fiberglass aeration or mineral tanks, 6" Diameter - 13" Diameter.

For a Period of FIVE YEARS: The fiberglass aeration or mineral tanks, 14" Diameter - Up.

For a Period of ONE YEAR: The Ozone Generator.

For a Period of ONE YEAR: The entire unit system ("System").

Any parts used for replacement are warranted for the remainder of the original warranty period for the applicable part.

THIS WARRANTY IS EFFECTIVE TO THE ORIGINAL CONSUMER PURCHASER ONLY, AND ONLY FOR AS LONG AS THE SYSTEM REMAINS AT THE ORIGINAL INSTALLATION SITE. COVERAGE TERMINATES IF YOU SELL OR OTHERWISE TRANSFER THE SYSTEM OR IF THE SYSTEM IS MOVED FROM THE ORIGINAL INSTALLATION SITE.

No sales representative, distributor, agent, dealer, reseller, authorized seller or any other person or entity is authorized to make any other warranty, or modify or expand the warranty provided herein on behalf of Hellenbrand. Upon expiration of the applicable warranty period, Hellenbrand shall have no further liability related to the System/parts to which the warranty period applies, except with respect to valid warranty claims asserted during the appropriate warranty period.

If the System or any part described above becomes defective within the specified warranty period, you should notify your local authorized seller of Hellenbrand products, and arrange a time during normal business hours for the inspection of the System at the original installation site. You may also contact Hellenbrand and we will provide you with the contact information for your local authorized seller of Hellenbrand products. Hellenbrand, at its option, will repair or replace the System or any part found defective within the terms of this warranty. You are responsible for freight from our factory and any service fees charged by the local authorized seller of Hellenbrand products for installation, repair, removal, replacement, service, etc., of any System or parts. This warranty does not include any labor charges. This paragraph sets forth the exclusive remedy for any valid warranty claims against Hellenbrand.

THIS WARRANTY DOES NOT COVER defects caused by sand, sediment or bacteria fouling, accident, fire, flood, Act of God, misuse, misapplication, neglect, alteration, installation or operation contrary to Hellenbrand's printed instructions, or installation, repair or service by anyone other than Hellenbrand or an authorized seller of Hellenbrand products.

IN ADDITION, THIS WARRANTY DOES NOT COVER UNPROTECTED OUTDOOR INSTALLATIONS. This System, including all of the electrical components, must be protected against windblown dust, falling and windblown rain, freezing temperatures and the formation of ice, with an appropriate enclosure consisting of a floor, roof, walls, ventilation and heat.

As a manufacturer, we do not know the characteristics of your water supply or the purpose for which you are purchasing this system. You should be aware that the quality of water supplies may vary seasonally or over a period of time, and that your water usage rate may vary as well. Water characteristics may change considerably if this System is moved to a new location. For these reasons, Hellenbrand assumes no liability for the determination of the proper equipment necessary to meet your needs; and Hellenbrand does not authorize others to assume such obligations for Hellenbrand.

TO THE EXTENT PERMITTED BY APPLICABLE LAW, REMEDIES FOR DEFECTS OR FAILURES ARE LIMITED TO THE REMEDIES PROVIDED IN THIS WARRANTY. THERE ARE NO EXPRESS WARRANTIES OTHER THAN THOSE SET FORTH HEREIN. ANY IMPLIED WARRANTIES, INCLUDING WITHOUT LIMITATION WARRANTIES OF MERCHANTABILITY, FITNESS FOR PARTICULAR PURPOSE, NON-INFRINGEMENT, OR ANY WARRANTIES ARISING FROM COURSE OF PERFORMANCE, COURSE OF DEALING, OR FROM USAGES OF TRADE, ARE LIMITED IN DURATION TO THE APPLICABLE WARRANTY PERIOD SET FORTH ABOVE.

UNDER NO CIRCUMSTANCES SHALL HELLENBRAND BE LIABLE TO THE ORIGINAL CONSUMER PURCHASER OR TO ANY OTHER PERSON FOR ANY INCIDENTAL, INDIRECT, SPECIAL OR CONSEQUENTIAL DAMAGES OR FOR ANY OTHER LOSS, DAMAGE, OR EXPENSE OF ANY KIND, INCLUDING LOSS OF PROFITS, WHETHER ARISING OUT OF BREACH OF WARRANTY, BREACH OF CONTRACT, IN TORT OR OTHERWISE, AND REGARDLESS OF WHETHER HELLENBRAND WAS AWARE OF THE POSSIBILITY OF SUCH LOSS. THESE LIMITATIONS WILL APPLY REGARDLESS OF ANY FAILURE OF ESSENTIAL PURPOSE OF ANY LIMITED REMEDY.

Some states do not allow limitations on how long an implied warranty lasts, so the above limitations may not apply to you. Similarly, some states do not allow the exclusion or limitation of incidental or consequential damages, so the above limitation or exclusion may not apply to you. This warranty gives you specific legal rights, and you may also have other rights which vary from state to state. Hellenbrand products are not for sale or distribution into the State of California effective 8/31/18.